

# Turbine mode start-up simulation of a FSFC variable speed pump-turbine prototype – Part I: 1D simulation

S Alligné<sup>1</sup>, A Béguin<sup>1</sup>, D Biner<sup>2,3</sup>, C Münch-Alligné<sup>2</sup>, V Hasmatuchi<sup>2</sup>, N Hugo<sup>4</sup>, F Avellan<sup>5</sup>, D Dujic<sup>3</sup>, C, Nicolet<sup>1</sup>

<sup>1</sup> Power Vision Engineering Sàrl, St-Sulpice, Switzerland

<sup>2</sup> Institute of Systems Engineering, School of Engineering, HES-SO Valais-Wallis, Rawyl 47, Sion, Switzerland

<sup>3</sup> Power Electronics Laboratory – PEL, Ecole Polytechnique Fédérale de Lausanne, Lausanne, Switzerland

<sup>4</sup> Alpiq SA, Lausanne, Switzerland

<sup>5</sup> Laboratory for Hydraulic Machines – LMH, Ecole Polytechnique Fédérale de Lausanne, Avenue de Cour 33 bis, 1007 Lausanne, Switzerland

E-Mail: [sebastien.alligne@powervision-eng.ch](mailto:sebastien.alligne@powervision-eng.ch)

**Abstract.** Variable speed hydroelectric units equipped with full size frequency converter (FSFC) offer high operational flexibility enabling fast operating point transitions which increase grid regulation capacities. The XFLEX HYDRO H2020 European research project aims to demonstrate flexibility of such technology at prototype scale. The Z'Mutt pumping station, part of the Grande Dixence hydroelectric scheme located in Switzerland, is one of the demonstrators focused on the FSFC technology with a new 5 MW reversible Francis pump-turbine which will be commissioned in 2021. This paper, divided in two parts, aims to simulate the turbine mode fast start-up sequence made possible with the use of a FSFC and to assess the unit damage by means of 1D and 3D CFD simulations. The part I of this paper presents the 1D hydraulic transient simulation results of start-up sequences of unit U5 considering both conventional fixed speed technology and variable speed technology. The time evolution of the unit's operating point is used as input data for 3D CFD simulations of part II, aiming to assess the impeller damage. Different control strategies to use the FSFC for turbine mode start-up sequence are analysed. Advantages and limits of each strategy are discussed, and recommendation is made for the Z'Mutt prototype demonstrator.

## 1. Introduction

The increasing contribution of intermittent new renewable energy sources in today's electricity mix emphasizes the importance of balancing resources in modern power grids. The XFLEX HYDRO H2020 European Project intends to consolidate the control capacities of hydropower plants and therefore its role in future power supply systems, see [1]. The aim of the project is to demonstrate capability of new key technologies such as smart control, variable speed hydroelectric units [2], hydraulic short circuit, and battery-turbine hybrids to improve grid regulation capacities. Seven European hydropower plants demonstrators serve as an experimental basis to assess advantages, limits and impacts of these different technologies. The Z'Mutt pumping station, as part of the Grande Dixence hydroelectric scheme in Switzerland, has been selected as one of the XFLEX HYDRO demonstrators. A new 5 MW reversible pump-turbine, planned to be commissioned by 2021, is equipped with a full-size frequency converter, FSFC and will be utilized in the XFLEX HYDRO project to assess flexibility offered by this technology.

The aspired flexible operation of modern hydropower units may lead to increased numbers of start and stop cycles and even transitions from generating to pumping mode, related to harsh operating conditions for the unit. To avoid premature fatigue of mechanical components, these transition phases will be optimized in the framework of the XFLEX HYDRO project to maximize the unit life-time. This optimization will be achieved by model tests (EPFL Technology Platform for Hydraulic Machines), 1D transient hydroelectric simulations (Power Vision Engineering), 3D CFD simulations and prototype field tests (HES-SO Valais-Wallis). The obtained findings will be integrated into advanced control algorithms driving the turbine regulator and the FSFC to optimize the life-time unit during these transition phases.

This paper, divided in two parts, aims to simulate the turbine mode fast start-up sequence made possible with the use of a FSFC and to assess the unit damage by means of 1D and 3D CFD simulations. The unit U5 of Z'Mutt power plant is taken as test case and comparison of impeller damage between conventional fixed speed technology and FSFC based variable speed technology will be performed. Between both technologies, different operating point evolutions with different durations are experienced. Consequently, the damage on the unit's components is different. Damage contributions of fixed speed turbine start-up sequences can be mitigated by tuning the guide vane start-up sequence [7]. In addition to this possibility, the FSFC technology enables the control of the rotational speed during start-up which may lead to further reduction of damages.

The part I of this paper presents the 1D hydraulic transient simulation results of start-up sequences of unit U5 in case of conventional fixed speed technology and variable speed technology. The time evolution of the unit's operating point is used as input data for 3D CFD simulations of part II, aiming to assess the unit damage. First, in part I, the control strategies used to start the unit U5 are presented for both technologies. Then, 1D hydraulic transient simulation of unit U5 start-up sequence is performed with the different control strategies. The related operating point trajectories in the N11-Q11 frame are compared to define the best and safest strategy to start the unit with the FSFC. These trajectories are finally used as input data for 3D CFD simulations of part II.

## **2. The Z'Mutt XFLEX HYDRO demonstrator**

The Z'Mutt pumping station, schematized in Figure 1, is composed of 5 units, namely four pumps with synchronous motors of 2 x 30 MW (U1, U2) and 2 x 14 MW (U3, U4), as well as a new reversible Francis pump-turbine of 5 MW (U5), planned to be commissioned by 2021. The new pump-turbine prototype, manufactured by CKD Blansko, will be equipped with an asynchronous motor-generator, driven by a full-size frequency converter, FSFC. The pump-turbine is characterized by a specific speed of  $n_q = 54$  and a unit mechanical time constant of  $\tau_m = 1.3s$ , while the nominal hydraulic data values of unit U5 are given in Table 1 for the pump mode.

The four main pumps U1234 are used to pump water from Z'Mutt reservoir and Bodmen basin to the Trift gallery feeding the main Grande Dixence reservoir. The unit U5 allows in pump mode to regulate the pumping discharge of units U34 coming from Bodmen by pumping water from Z'Mutt. If units U34 are at stand-still water is directly pumped from Z'Mutt reservoir to Bodmen. In turbine mode, it allows to regulate pumping discharge of units U12 coming from Z'Mutt by pumping water from Bodmen. This new unit is mainly used for regulation purpose of incoming flow fluctuating along the year. Therefore, high flexibility is required and the use of FSFC is justified. This operation mode induces large number of starts and stops of the unit and can be up to 80 times in August when incoming flow is important due to melting snow.

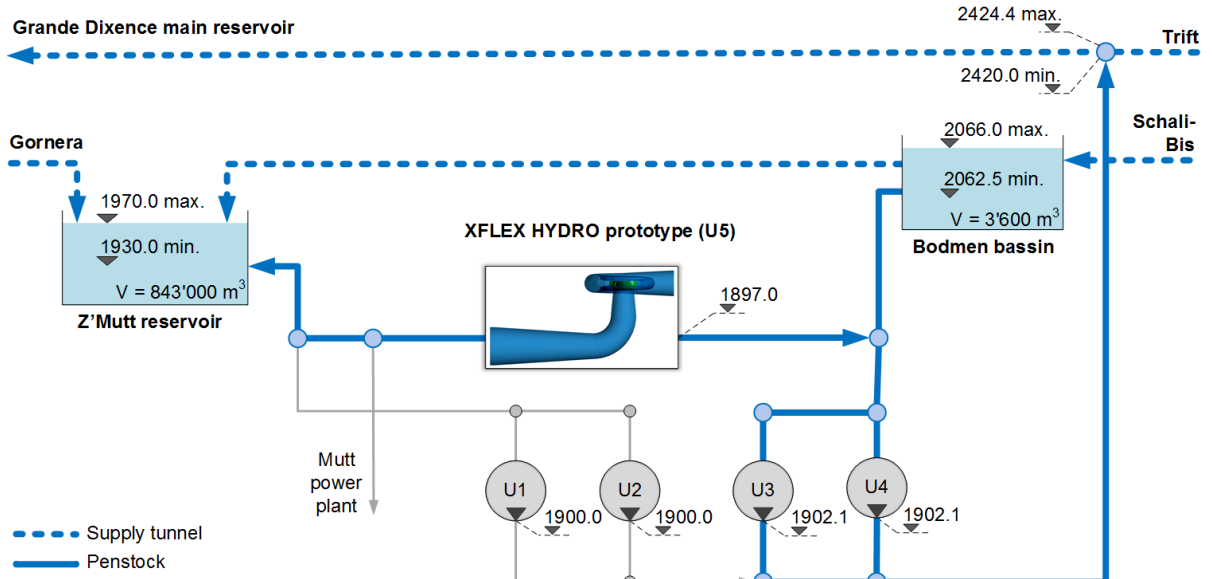

Figure 1: Schematic of the Z'Mutt pumping station.

Table 1: Nominal hydraulic data values of unit U5 in pump mode.

Data	Unit	Value
Qn	m <sup>3</sup> /s	3.6
Hn	m	115
Nn	rpm	1000
Dref	m	0.9
Pn	MW	4.5
nq	-	54
J <sub>tot</sub>	kg·m <sup>2</sup>	535
τ <sub>m</sub>	s	1.3

### 3. Control Strategies for turbine start-up

#### 3.1. Fixed speed technology

A schematic block diagram of the starting control strategy with fixed speed technology is shown in Figure 2. At the beginning of the start-up sequence of a turbine with a fixed speed technology, the motor-generator is disconnected from the grid because of the open circuit breaker. The electro-magnetic torque ( $t_{em}$ ) of the motor-generator is null. During this first stage, the rotational speed of the group is controlled by the turbine speed regulator which acts on the guide vane opening of the turbine. This turbine speed regulator drives the rotational speed to a value very closed to the synchronous speed. Once the rotational speed is closed to the synchronism, the voltage regulator at the rotor ensures a stator induced voltage magnitude identical to the grid. When the frequency, magnitude and phase of stator's voltage match with grid's voltage, the circuit-breaker is closed and the motor-generator is connected to the grid. The motor-generator can then transform the mechanical power into electrical power and inject it into the grid. The synchronization process before connection to the grid can take couples of minutes and is damaging for the pump-turbine which is subject to significant pressure fluctuations [8]. Indeed, the stabilization at "speed no-load" condition induces rotating stall, flow separation and recirculation, and stochastic pressure fluctuations developing in pump-turbine impeller.

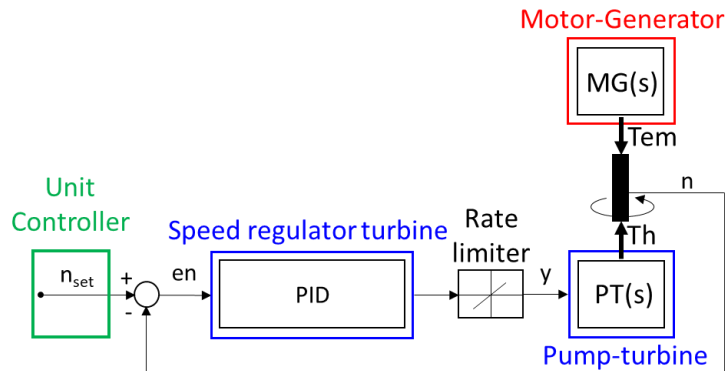

Figure 2: Schematic block diagram of the speed control strategy used for turbine mode start-up with fixed speed technology.

### 3.2. Variable speed technology with full size frequency converter

With variable speed technology, in contrary to the start-up sequence with fixed speed technology, the motor-generator can be connected to the grid while the pump-turbine is at stand-still with closed guide vanes and no rotational speed. This is due to the fact that the power converter, between the motor-generator and the grid, ensures the frequency decoupling of both sides. By consequence, electro-mechanical synchronization process as described in 3.1. is not required anymore and “speed no load” condition of the pump-turbine can be avoided. Hence, the use of the FSFC can help to reduce damage of the unit. Moreover, the synchronization between motor-generator and the grid is quasi-instantaneous because it only relies on one control function, the so-called ‘Phase Locked Loop’ (PLL) in the FSFC controller. This is another advantage of the FSFC technology, which allows starting injecting power from the beginning of the start-up sequence.

The FSFC and its controller offer two built-in control modes: either the converter controls the speed or it controls the electro-magnetic torque of the motor-generator it is connected to. For U5 of Z’Mutt, both of these modes will be available in the FSFC. Based on these two FSFC control modes, two start-up control strategies have been explored in the work presented in this paper. These two strategies are shown respectively in Figure 3 and in Figure 4.

The first control strategy, illustrated in Figure 3, uses the speed regulator of the FSFC to control the speed, and the turbine governor is used in guide vane position control mode (controlling servo-motors). The set points for the speed regulator and for the guide vane positioning control come from the speed optimizer block. For a given turbine power set point ( $P_{set}$ ) and given net water head ( $H_{net}$ ), the speed optimizer block computes optimal speed ( $n_{opt}$ ) and optimal guide vane opening ( $y_{opt}$ ). The speed optimizer is based on the efficiency hill charts of the turbine. The rate of change of the rotational speed set point and of the guide vane opening set points are limited. The rate of change limitation for the speed set point is a parameter of the start-up sequence optimization. The rate of change of guide vane opening is limited by the safety mechanical maneuvering time defined to respect extreme pressures in hydraulic system and overspeed of the unit during transient emergency shutdown. Guide vanes maneuvering time of unit U5 is 20s for 100% opening variation.

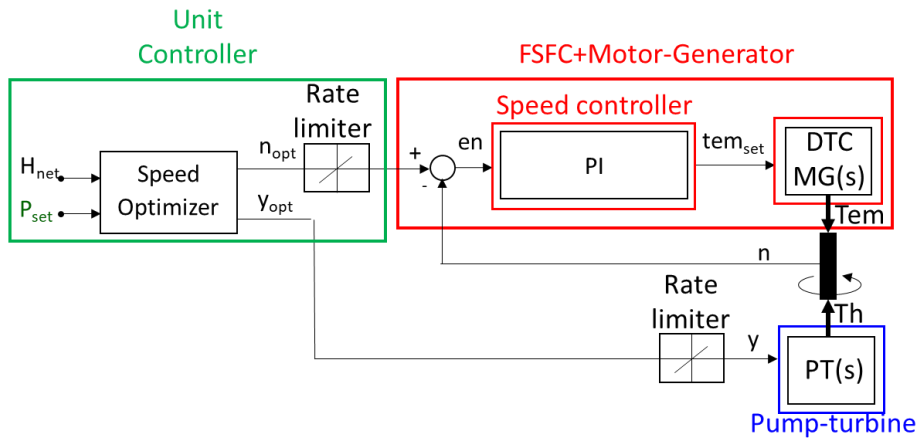

Figure 3: Schematic block diagram of the starting control strategy with full size frequency converter in speed control mode.

The second control strategy, illustrated in Figure 4, uses the torque regulator of the FSFC to control the electro-magnetic torque ( $T_{em}$ ), and the turbine governor is still used in guide vane position control mode (controlling servo-motors). Hence, in this strategy, the speed is not controlled. The torque set point for the torque regulator is computed from the power set point ( $P_{set}$ ) and the desired final optimal speed  $n_{opt}$  using the relation  $T_{em,set} = P_{set}/n_{opt}$ . The optimal speed ( $n_{opt}$ ) and the corresponding guide vane opening ( $y_{opt}$ ) set points come from the speed optimizer block, similarly to first strategy. The rate of change of the torque set point as well as for the guide vane opening set point are limited. The rate of change limitation of the torque set point is a parameter of the optimization of the start-up sequence. The rate of change of guide vane opening is limited by the safety mechanical manoeuvring time like for the first control strategy.

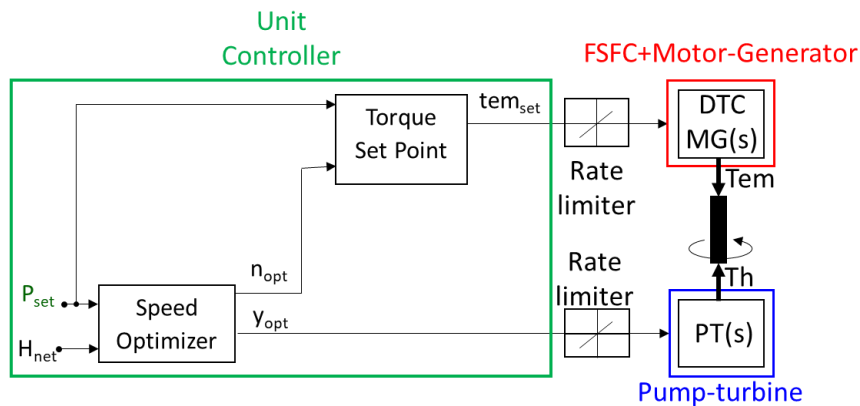

Figure 4: Schematic block diagram of the starting control strategy with full size frequency converter in torque control mode.

#### 4. 1D simulations of turbine start-up sequence of unit U5

##### 4.1. SIMSEN model of Z'Mutt power plant

A SIMSEN model of the Z'Mutt power plant has been implemented and validated with measurements of separate emergency shutdowns of unit U1 and unit U3 performed in May 2013. This model includes the reservoirs, the adduction system, the four pumps U1-U4 and the new reversible pump-turbine U5. Based on this validated model, simulation of turbine mode start-up sequence of unit U5 is performed at maximum head for the different control strategies presented in Section 3. . The

output power unit is set to 4.1MW after start-up. For the modelling of the hydraulic control part, the turbine speed regulator of unit U5 is implemented in case of fixed speed regulator, whereas for the variable speed technology, a linear guide vane opening is imposed. Its rate of change is defined as the safety mechanical maneuvering time of the servomotor which is the quickest opening rate. Control part of the FSFC is modelled with a simplified approach by applying an electromagnetic torque on the rotating mass of unit U5 to achieve the expected rotational speed time evolution. This simplified approach has been previously validated by comparing transients of fast transition pump-turbine modes with a detailed hydroelectric model [9]. Time evolution of the rotational speed set point is linear during the start-up sequence and its rate of change is set, after optimization, about 9 s for 1000 rpm variation. In torque control mode, the torque set point is defined either as linear in time or as a step function. Both cases are simulated and compared. The dynamic of the FSFC torque controller and of the motor-generator is modelled by a first order transfer function between the set point and the resistive torque on the rotating mass with a time constant set to 100ms.

The simplification of the FSFC modelling within this work is justified by the fact that the response time of the FSFC and its controllers is much faster than the time constants on the hydraulic and mechanical side. Indeed, the torque controller of the FSFC installed in U5 uses the so-called ‘Direct Torque Control’ (DTC) method. In DTC, the torque deviation from the set point is converted into a binary value, which triggers the application of either the full positive or the full negative voltage on the stator of the motor-generator. This method allows reaching quite fast the torque desired but induces on the other hand torque ripples. These ripples are nevertheless minimized by optimal settings of DTC control parameters. Concerning the internal operation of the speed regulation mode of the FSFC, one can say that it is a PID controller, which output is a torque set point fed directly into the DTC controller. Performances of this speed controller are also considered good enough to be approached as linear ramps of speed in the present model.

#### 4.2. Turbine mode start-up simulation results

Figure 5 shows transient results of the pump-turbine and of the motor-generator simulated with the different control strategies described in Section 3. during the turbine mode start-up sequence.

With the fixed speed technology, the turbine start-up duration is 50s to reach 95% of the power set point value. The turbine speed regulator acts on the guide vane opening to stabilize the unit at “speed no load” condition corresponding to synchronous rotational speed with the grid frequency and no mechanical torque on the runner. During this stabilization, the synchronization process with the grid in terms of voltage amplitude and phase is performed. A duration of synchronization of 15s is assumed but can take longer, up to several minutes. Once the unit is connected to the grid, the output power is increased as fast as possible by opening the guide vanes on the safety maneuvering time of the servomotor.

For FSFC technology, the simulated start-up sequence begins with the assumption that the FSFC controller is ready, i.e. that its synchronization controller (PLL, see Section 3.2. ) is initialized. As this is quasi-instantaneous, this has no interest in this scenario. Once FSFC is ready, the guide vanes are opened as fast as possible on the safety maneuvering time of the servomotor. The transients of the start-up sequence, in particular the evolution of the rotational speed, depend on the start-up strategy:

- In speed control mode, the rotational speed set point sent to the FSFC is increased linearly and delayed with respect to the guide vane opening by 2s. This delay is implemented to avoid electrical consumption from the grid ( $p_{elU5} > 0$ ) to increase rotational speed of the unit because of limited mechanical torque on the impeller at low guide vane opening. Moreover, the linear variation of rotational speed set point is smoothed with a low pass filter to avoid jumps of electromagnetic torque induced by the sudden change of rotational speed set point. The rate of change of rotational speed set point is calibrated to reach at the end of the start-up sequence, optimal guide vane opening and rotational speed provided by the speed optimizer for the desired output power. This time

synchronization between optimal guide vane opening and rotational speed is ensured when the unit is started and set to maximum output power at maximum head. Maximum head has been chosen for time synchronization since at minimum head it would induce higher solicitation on the shaft with higher torque variation values.

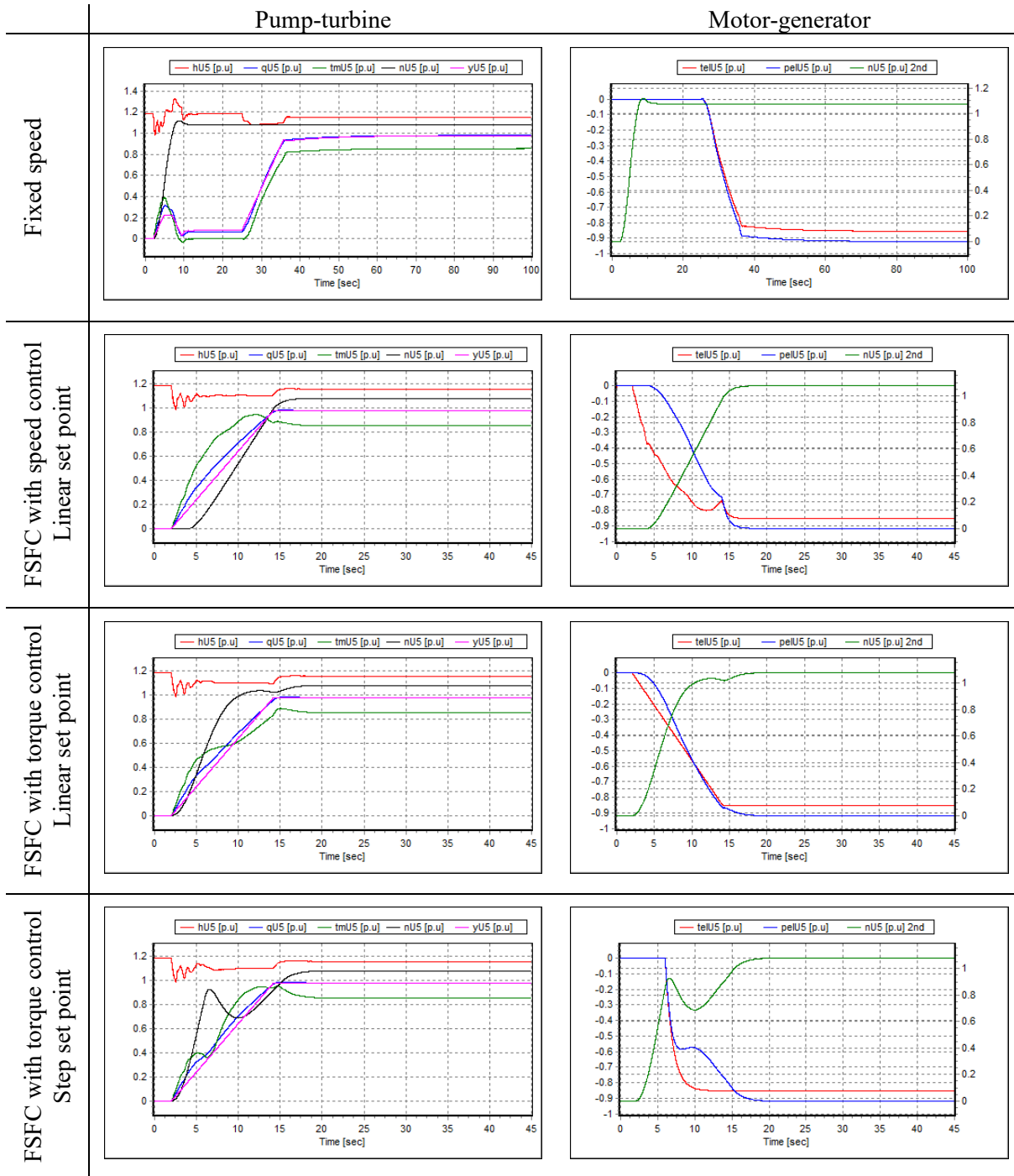

Figure 5: Comparison of the pump-turbine transient (Left: head  $h_{U5}$ , discharge  $q_{U5}$ , mechanical torque  $tm_{U5}$ , rotational speed  $n_{U5}$ , guide vane opening  $y_{U5}$ ) and motor-generator transient (Right: electromagnetic torque  $tel_{U5}$  and power  $pel_{U5}$ ) simulated with the different control strategies.

- In torque control mode, the electromagnetic torque set point to the FSFC is increased linearly at the same time as the guide vane opening. Contrary to the speed control mode, the rotational speed is uncontrolled since it results from the balance between mechanical and electromagnetic torques. Non-linear variation of the rotational speed is experienced. This behavior of uncontrolled rotational speed evolution is emphasized if the electromagnetic torque set point to the FSFC is a step function. Moreover, a time delay of 4 s between the torque set point step and the guide vane opening start is introduced to prevent the unit to start in pump mode.

#### 4.3. Comparison of operating point trajectories in pump-turbine characteristic

Figure 6 shows the operating point trajectories in the N11-Q11 frame of the unit U5 induced by the turbine mode start-up sequence for different control strategies. Start-up with the FSFC allows to avoid the “speed no-load” area. Therefore, the unit damage would be reduced drastically. The part II of this paper is aiming to compare the unit damage between conventional fixed speed and variable speed start-up sequences by means of 3D CFD simulations. The operating point trajectory is used as input to define boundary conditions of CFD simulations. For the variable speed start-up, the trajectory with the FSFC in speed control mode is completely under control. Hence, this control mode will be used on site to start the unit and its related trajectory is selected for CFD simulations in part II. The torque control mode is dismissed since uncontrolled transient trajectory of the pump-turbine could be experienced. Indeed, the trajectory could be modified by the operation or any undesired transient of the other units of the power plant.

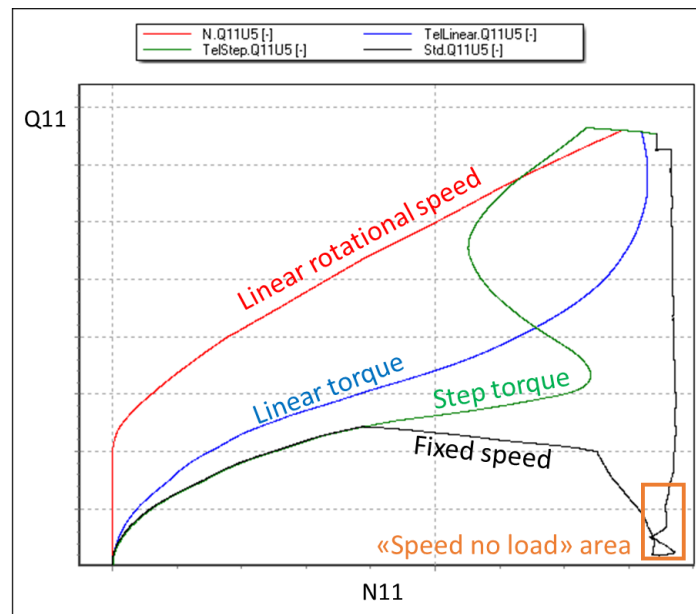

Figure 6: Comparison of operating point trajectories in N11-Q11 frame obtained with the different control strategies.

By controlling the rotational speed with the FSFC and the guide vane position with the turbine governor, any trajectory can be achieved. Further investigations in the XFLEX HYDRO project are in progress to define an optimal trajectory to minimize unit damage during the start-up sequence. By means of reduced scale model tests and 3D CFD simulations, a surface damage will be built and used as input for optimization of trajectory. A nonlinear rotational speed set point variation could be used to avoid area featuring high damage for the unit.



## 5. Conclusion

1D transient simulations of a pump-turbine start-up in turbine mode with the use of a FSFC have been performed and compared to a conventional fixed speed start-up. Two major control strategies to start the unit with the FSFC have been simulated. Either a rotational speed set point profile or an electromagnetic torque profile is given to the FSFC. In case of rotational speed control mode of the FSFC a linear set point variation is imposed. In torque control mode, two set point profiles have been tested: a linear profile and a step function profile. It has been shown that the speed control mode is safer in terms of pump-turbine transient during the start-up sequence since the operating point trajectory in the N11-Q11 frame is completely under control. In torque control mode the trajectory could be modified by the operation or any undesired transient of the other units of the power plant. This could induce excursion in area of turbine characteristic where damage could be important or may lead to unwanted water hammer phenomena. Finally, the operating point trajectories with fixed speed and with FSFC in speed control mode are selected for part II of this paper to assess benefits of FSFC on damage unit by means of 3D CFD simulations.

## 6. Acknowledgements

The Hydropower Extending Power System Flexibility (XFLEX HYDRO) project has received funding from the European Union's Horizon 2020 research and innovation programme under grant agreement No 857832. The authors would like to thank CKD Blansko and Hydro Exploitation SA for their collaboration and support.

## References

- [1] <https://xflexhydro.net/>
- [2] T. Kuwabara, A. Shibuya, H. Furuta, E. Kita, K. Mitsuhashi, Design and Dynamic Response Characteristics of 400 MW Adjustable Speed Pumped Storage Unit for Ohkawachi Power Station, IEEE Transactions on Energy Conversion, Vol. 11, Issue 2, pp. 376-384, June 1996.
- [3] E. Kopf, S. Brausewetter, M. Giese, F. Moser, Optimized control strategies for variable speed machines, In Proceeding of the 22nd IAHR Symposium on Hydraulic Machinery and Systems, Stockholm, Sweden, June-July 2004.
- [4] Y. Pannatier, B. Kawkabani, C. Nicolet, J.-J. Simond, A. Schwery, P. Allenbach, Investigation of control strategies for variable speed pump-turbine units by using a simplified model of the converters, IEEE Transactions on Industrial Electronics, Vol. 57, Issue 9, 2010, pp: 3039-3049.
- [5] J. Hell, M. Egretzberger, A. Lechner, R. Schürhuber, Y. Vaillant, Full size converter solutions for pumped storage plants – a promising new technology, Hydro 2012, Euskalduna Congress Centre Bilbao, Spain, 29-31 October 2012.
- [6] H. Schlunegger, A. Thöni, “100MW full-site converter in the Grimsel 2 pumped-storage plant”, Innsbruck, Hydro 2013.
- [7] J. Löfflad, M. Eissner, Lifetime assessment and plant operation optimization based on geometry scan and strain gauge testing – START/STOP optimization, 10th International conference on hydraulic efficiency measurements, Itajuba, Brazil, 2014.
- [8] V. Hasmatuchi, J. Decaix, M. Titzschkau, O. Pacot, C. Münch-Alligné, Detection of harsh operating conditions on a Francis prototype based on in-situ non-intrusive measurements, Proceedings of Hydro 2019, Porto, Portugal.
- [9] C. Nicolet, O. Braun, N. Ruchonnet, A. Béguin, F. Avellan, Full Size Frequency Converter for Fast Francis Pump-Turbine Operating Mode Transition, Proceedings of HYDROVISION International 2016, July 26-29, 2016, Minneapolis Convention Center, Minneapolis, MN, USA.